

KGK JET HQ1000

This high-quality 600 dpi inkjet printer delivers simple, reliable printing at an affordable price.



<http://www.kishugiken.co.jp/ew/>

Simple Easy Beautiful

Announcing a feature-packed and affordable inkjet printer under the KGK brand



* The installation stand is optional.

• High-quality 600 dpi inkjet printer at an affordable price

- The printhead uses a 300-dot 600-dpi nozzle-integrated ink cartridge for high quality printing.
- Allows for beautiful printing of not only dates and lot numbers, but QR codes, Data Matrix codes, and all kinds of barcodes.

• Newly-developed ink solves poor print quality issues occurring after downtime

- Traditional water-based ink often causes poor print quality (fragmented characters at the head of text strings) when the printer resumes printing after a pause for only a few minutes, resulting in product and ink loss. The printer uses a newly-developed ink that is able to significantly reduce this problem. A standard nozzle cap can be attached for further peace of mind when the printer will be down for a long period of time.

• One-touch cartridge replacement

- The nozzle can be replaced along with the ink cartridge, so customers can quickly resolve nozzle problems.
- Cartridges are extremely simple and easy to replace. Cartridges can be replaced by anyone with a single operation, without even dirtying their hands.

• Extremely simple configuration and operation

- The 5.7-inch full color touch panel offers an easy-to-read screen layout and allows for intuitive operation.

• Complete with ink cartridge management functions

- Ink cartridges feature onboard memory and are controlled through automatic computerized management. In addition to low ink management, these functions also prevent problems resulting from using old or unsuitable ink.



▲ Installing a cartridge



▲ Opening/closing the nozzle



▲ Screen example

• Printing sample Maximum print height 12.7 mm



▲ Two-line printing



▲ Barcode printing available

• Specifications

Item	HQ1000
Printing method	Drop-on-demand heat-transfer printing system
Max. supported line speed	30 m/minute (at 600 dpi)
Nozzle arrangement	300 dots, 600 dpi
Ink ejection direction	Horizontal, downward
Print height	12.7 mm (maximum)
No. of heads	1
Ink type	Black: TK402
Substrate detection	Photoelectric sensor
No. of printable lines	Four lines (maximum)
No. of printable messages	1,000 messages (maximum)
No. of modules per message	32 modules (maximum)
No. of characters per module	256 characters (maximum) (for text module)
Character type	Alphanumeric characters, symbols, hiragana, katakana, kanji (JIS first/second)
Character font	TrueType fonts (Gothic, Mincho)
Date/time printing	Year (western/Japanese), month, date, time (12/24, minutes, seconds, day of week)
Numbering	Max. of 10 digits (up/down), repeat, increment value setting, zero suppression
Barcode	ITF, Code 39, NW-7, JAN, Code 128
Two-dimensional code	QR, Data Matrix, PDF417

• Extended unit (optional)

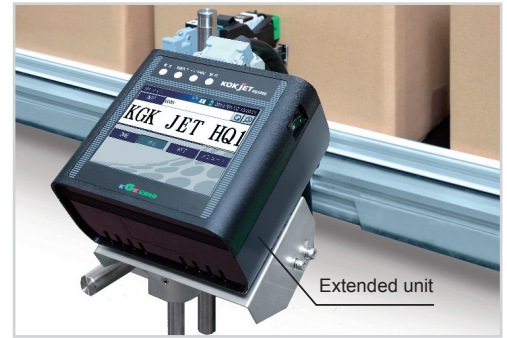

The optional extended unit adds even more functions.

[I/O] Even more versatile than the standard I/O.

[Encoder] Automatically tracks variations in conveyor belt speed.

[RS232C] Allows for serial communication with a PC or PLC.

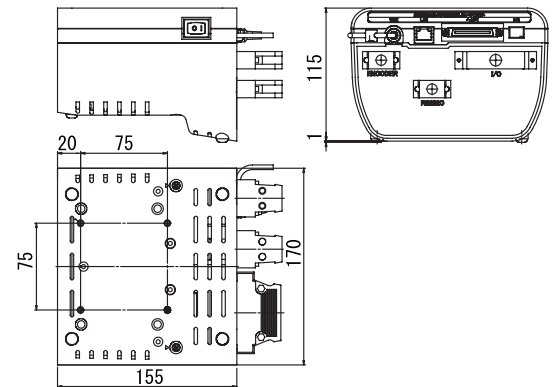

• Dimensional drawing

Units are expressed in millimeters.

[Controller]

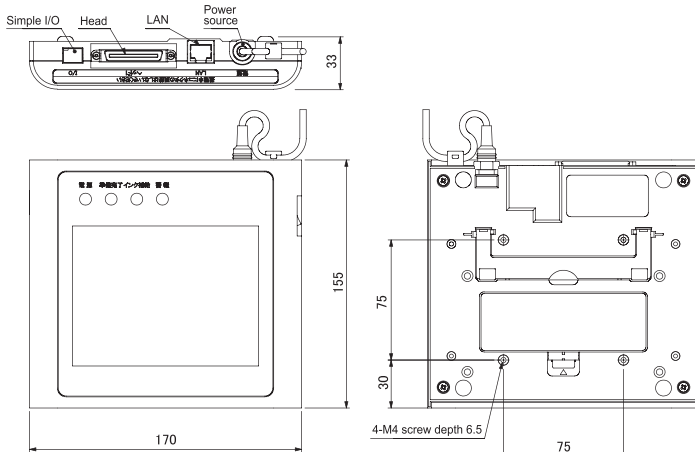

[Head section]

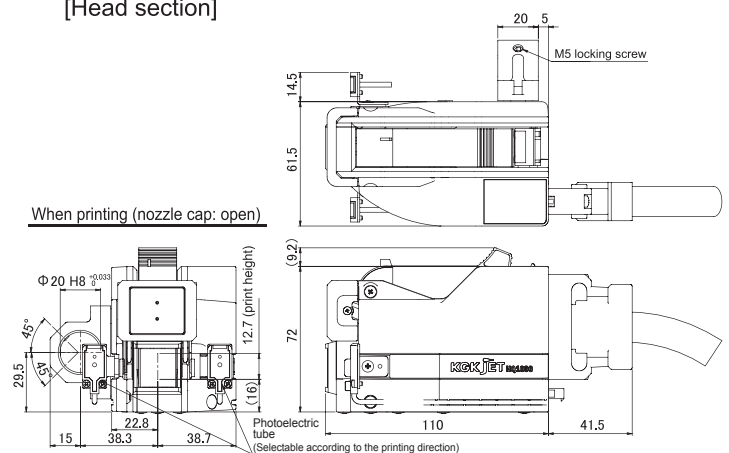

Product specifications may change without advance notice.