

# RTA400/420/401/421型寸法図

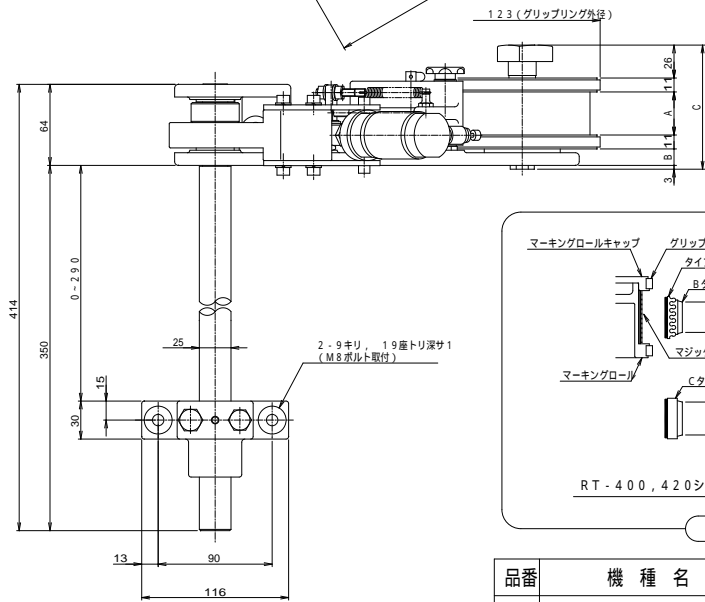

標準取付スタンド

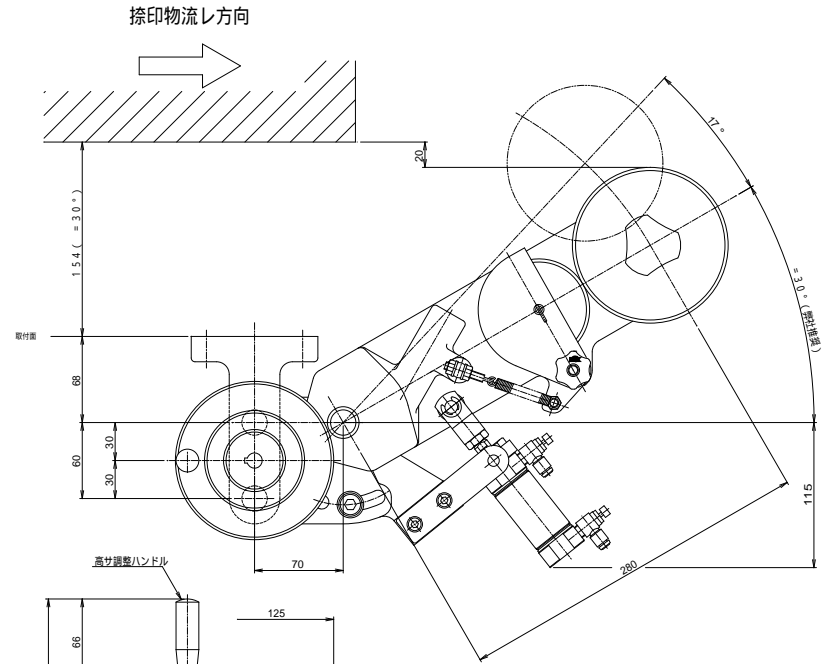
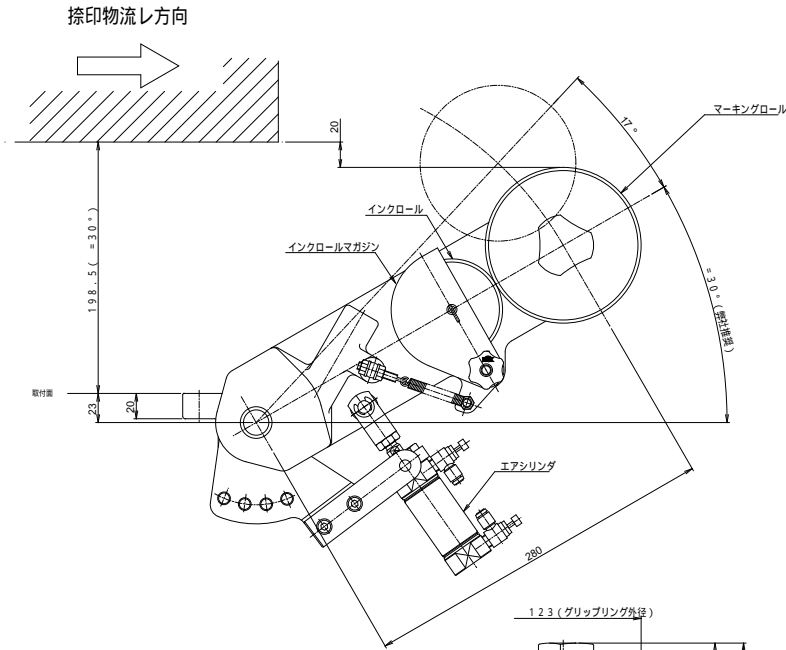
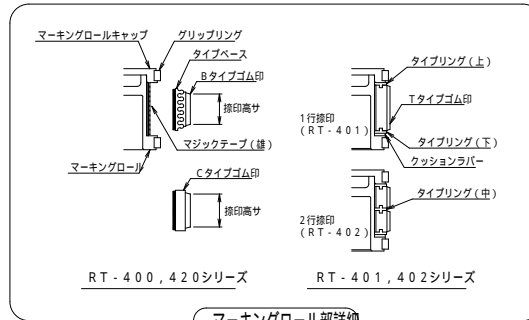

品番	機種名	インクロール幅(mm)	A寸法(mm)	B寸法(mm)	C寸法(mm)
1	RTA-400-30L(R)	30	34	13	98
2	RTA-400-40L(R)	40	42	14	107
3	RTA-420-60L(R)	60	62		127
4	RTA-420-80L(R)	80	82		147
5	RTA-420-100L(R)	100	102		167
6	RTA-420-120L(R)	120	122		187

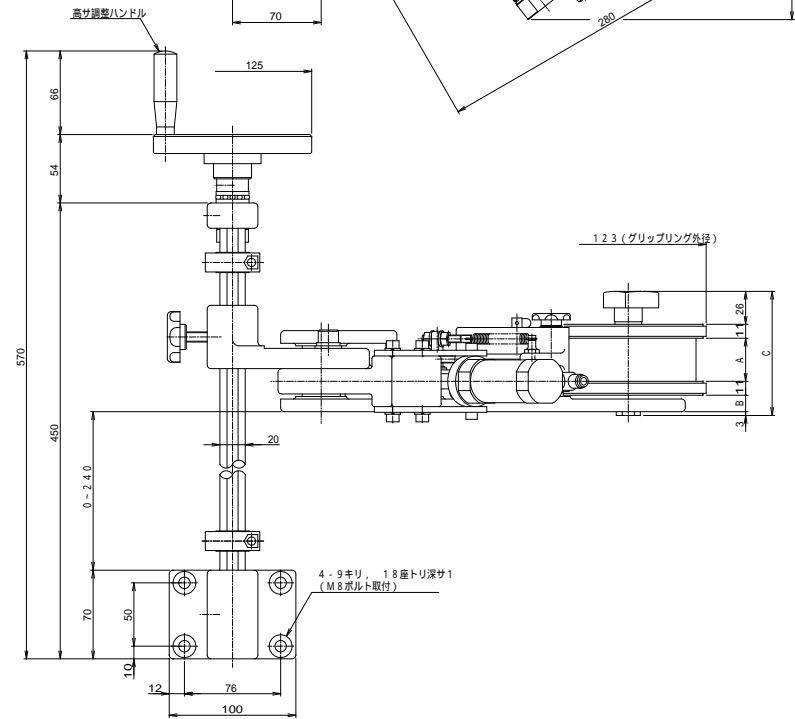

高さ調整スタンド (オプション)